

LIST OF CONTENTS / SCHEMATIC DIAGRAMS

Block Diagram of Baseband (Version 4.0 Edit 152) for layout version 04	2/A3-1
Circuit Diagram of Power Supply (Version 4.0 Edit 49) for layout version 04.....	2/A3-2
Circuit Diagram of Line Adapter Power Supply (Version 4.0 Edit 111) for layout version 04.....	2/A3-3
Circuit Diagram of 2 to 4 Wire Interface (Version 4.0 Edit 137) for layout version 04.....	2/A3-5
Circuit Diagram of Connectors (Version 4.0 Edit 73) for layout version 04	2/A3-5
Circuit Diagram of MCU Memory Block (Version 4.0 Edit 58) for layout version 04	2/A3-6
Circuit Diagram of Audio (Version 4.0 Edit 97) for layout version 04.....	2/A3-7
Circuit Diagram of ASIC (Version 4.0 Edit 54) for layout version 04.....	2/A3-8
Circuit Diagram of DSP Memory Block (Version 4.0 Edit 40) for layout version 04	2/A3-9
Circuit Diagram of RFI (Version 4.0 Edit 79) for layout version 04.....	2/A3-10
Circuit Diagram of Receiver (Version 4.0 Edit 234) for layout version 04	2/A3-11
Circuit Diagram of Transmitter (Version 4.0 Edit 292) for layout version 04	2/A3-12
Layout Diagram of WT9 (Version 04).....	2/A3-13

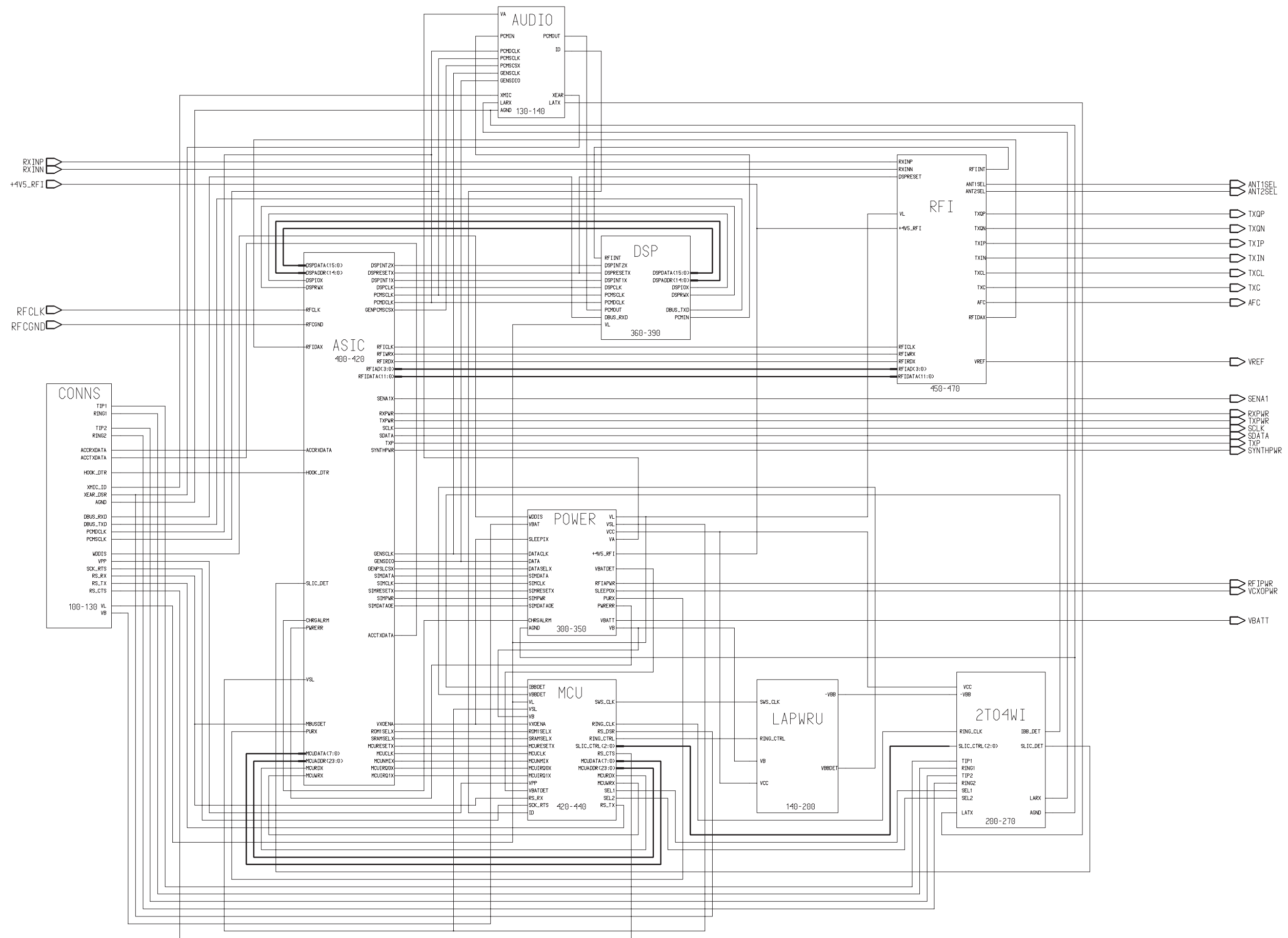

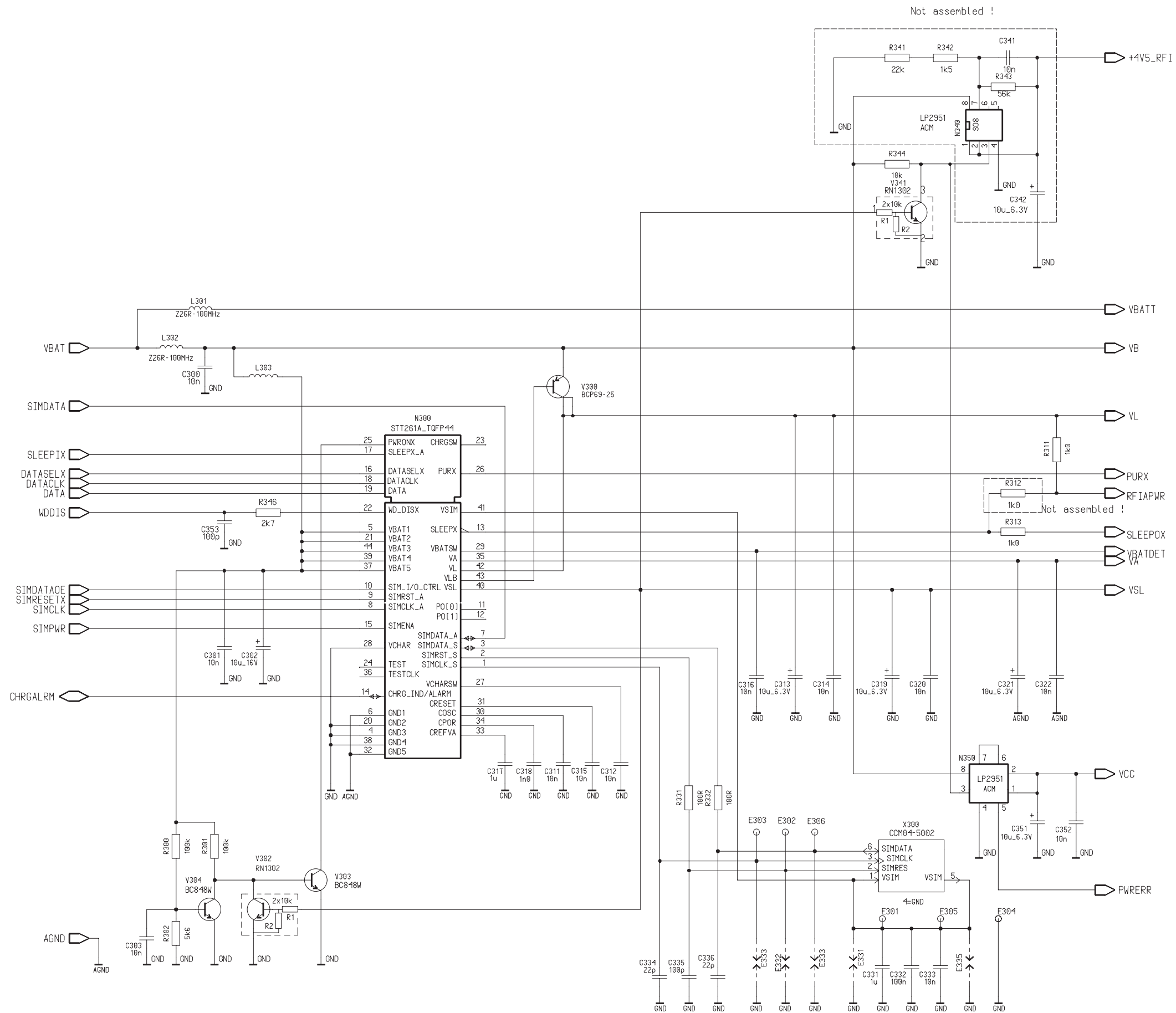

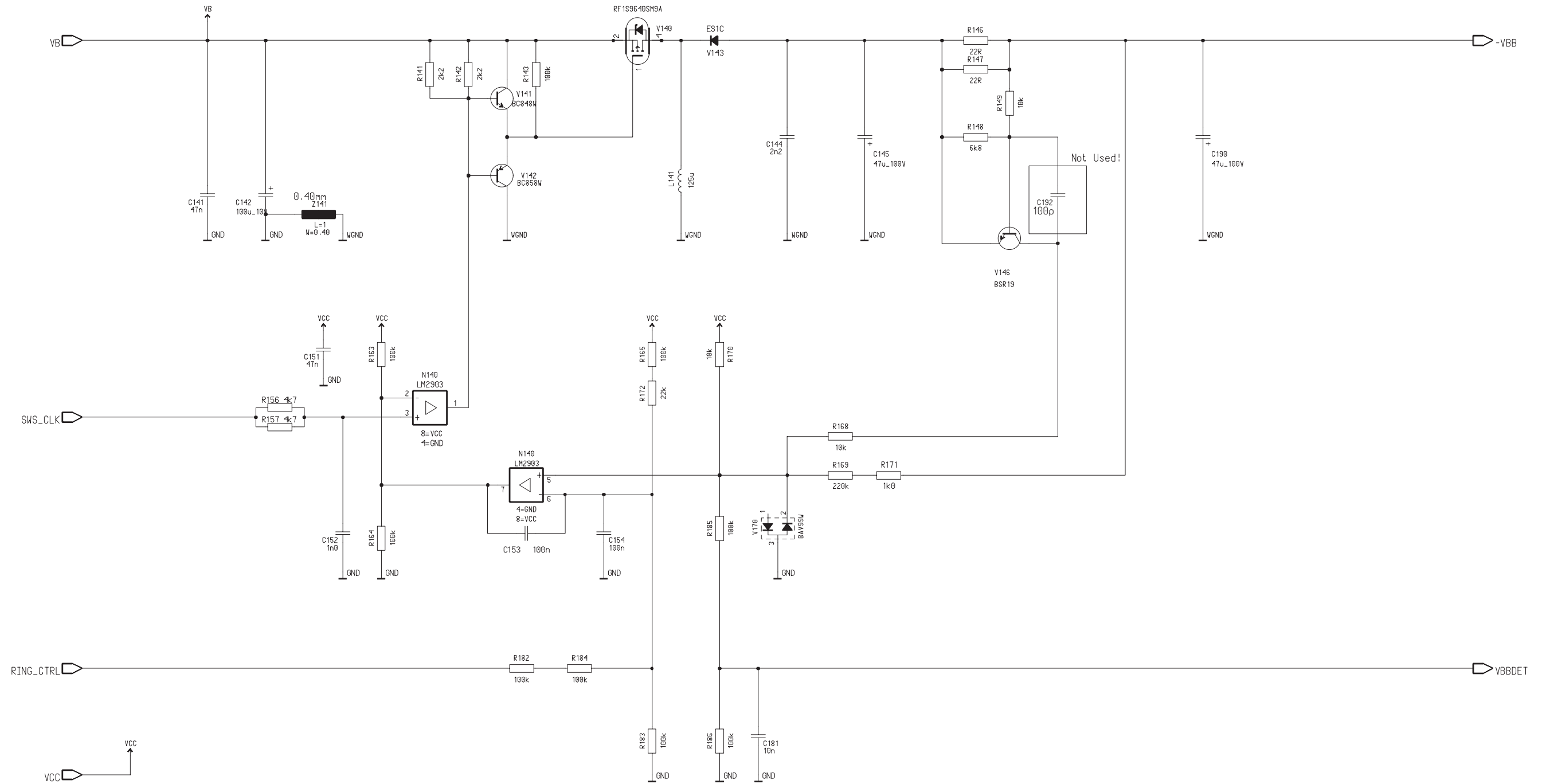

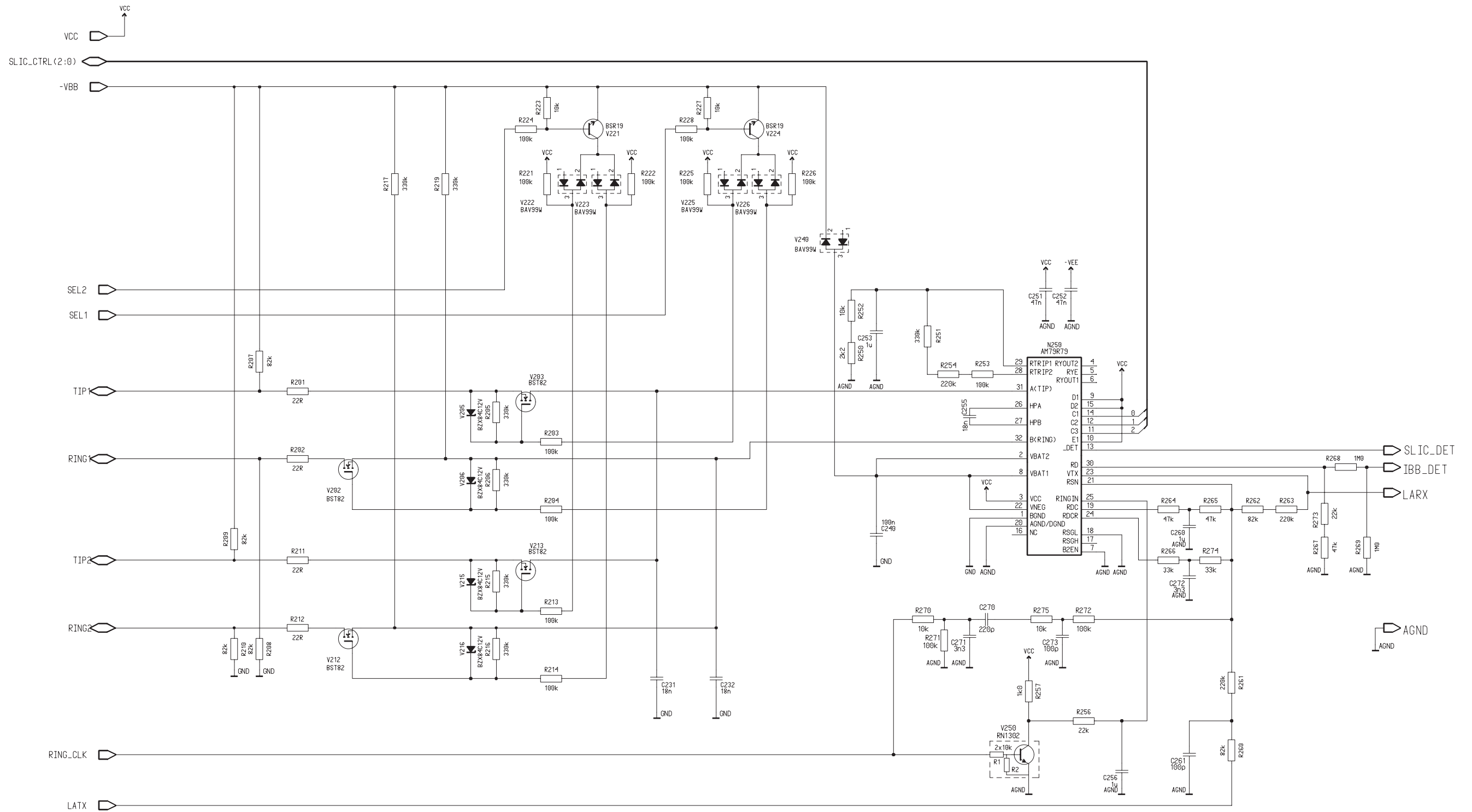

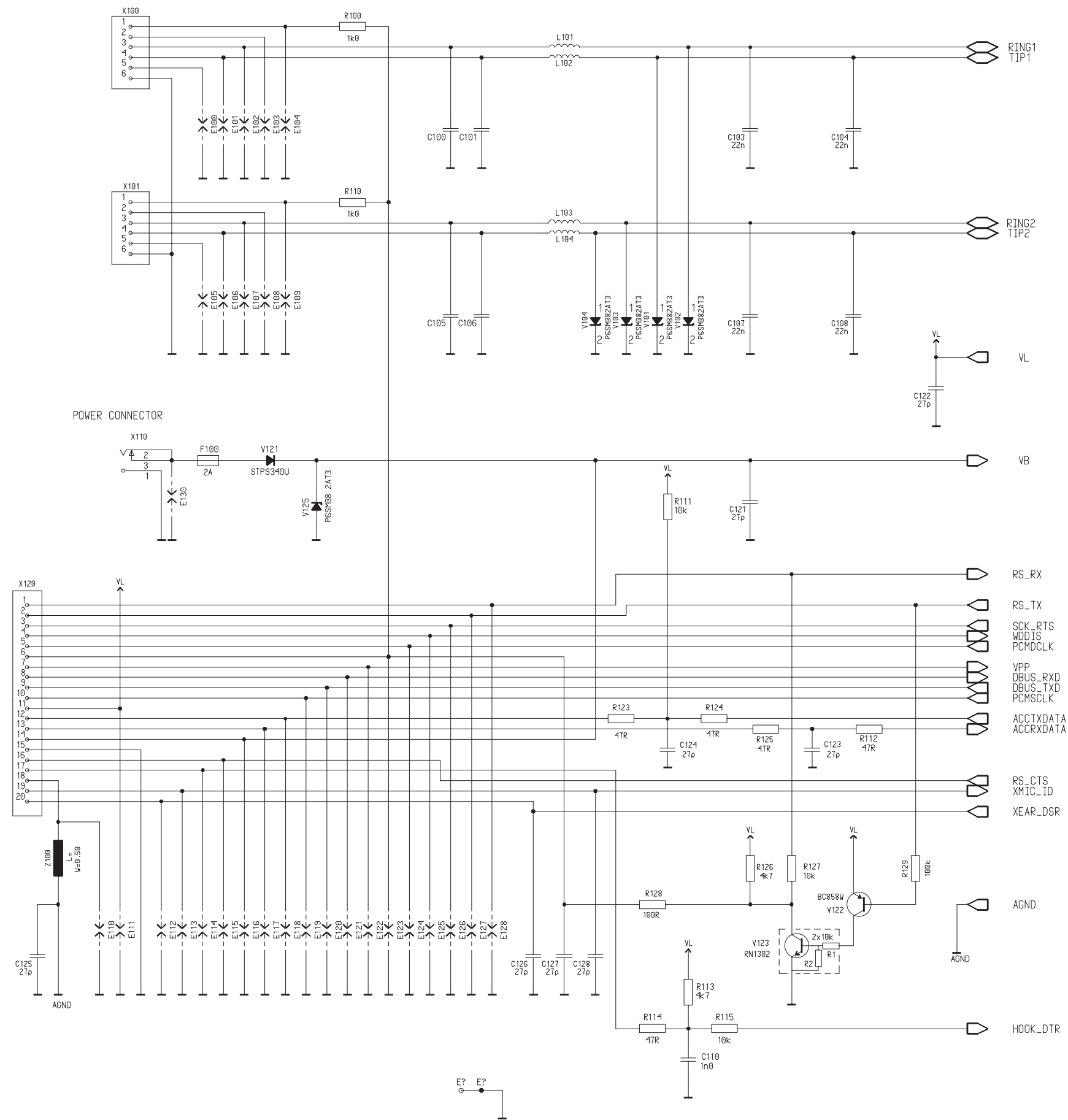

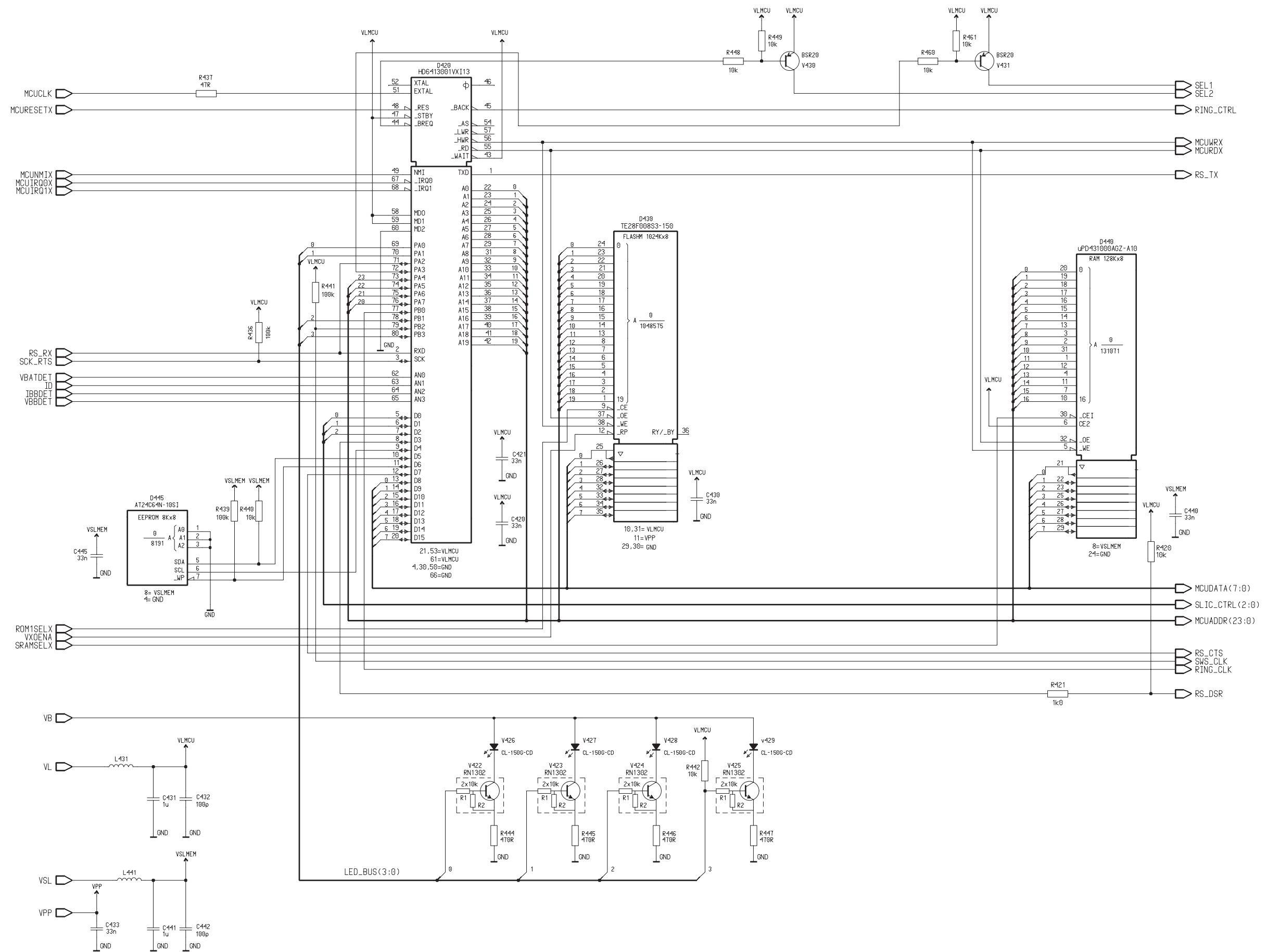

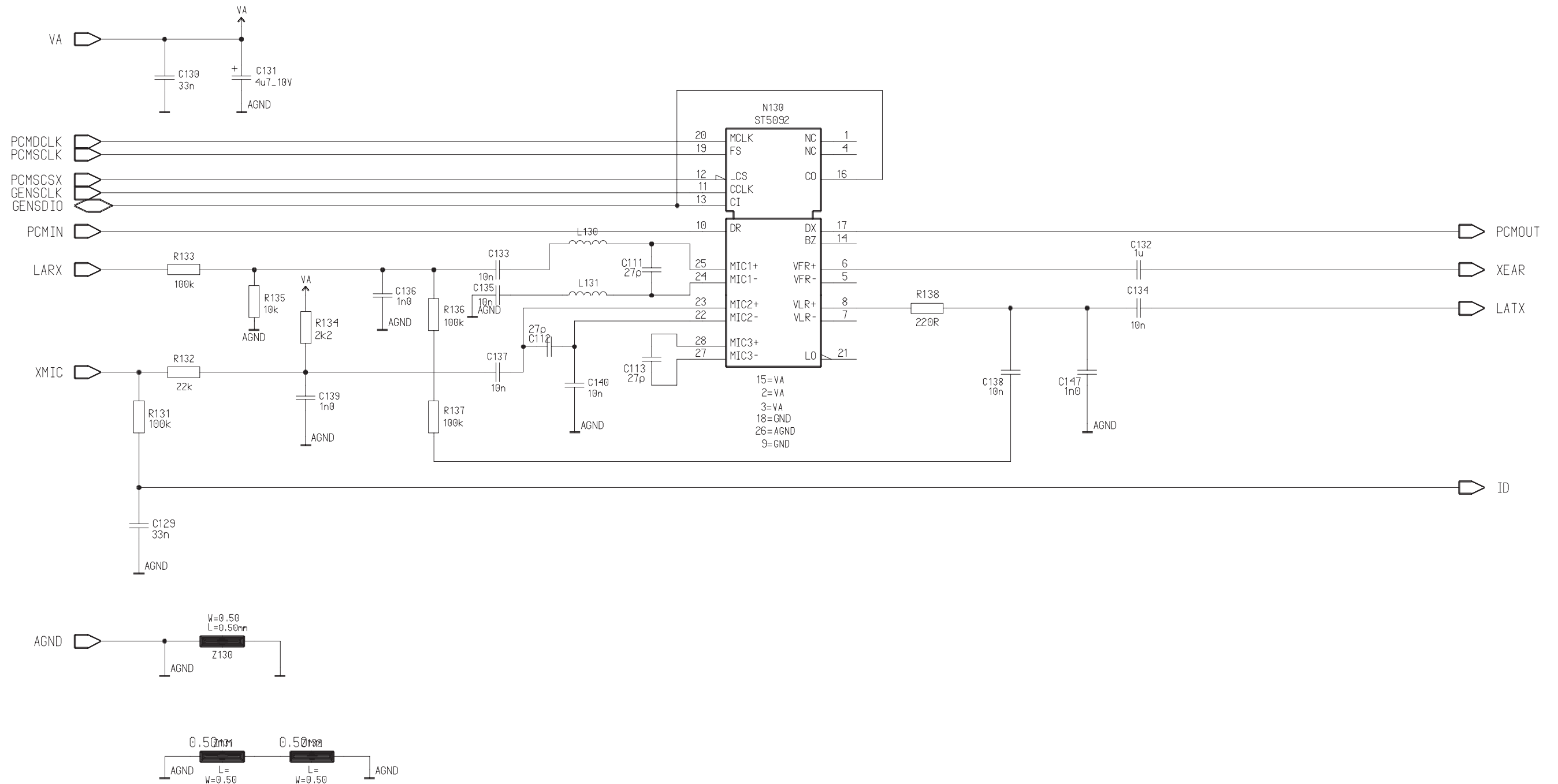

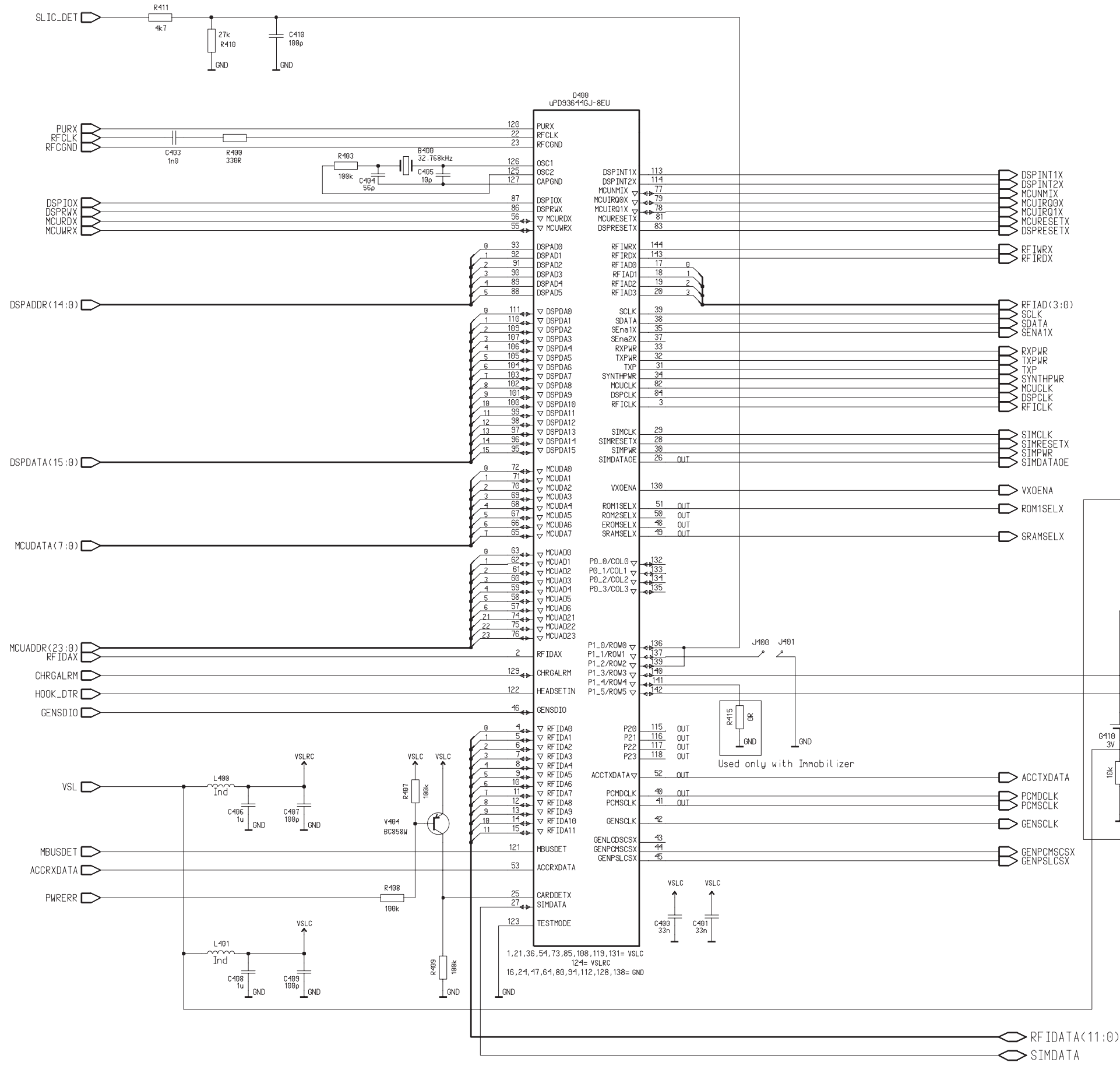

Used only with Immobilizer !

